

An Efficient comparison of MIMO OFDM Channel Estimation Algorithm

Dr.MINAL SAXENA, Prof. NAVNEET KAUR, Ms. SWATI PATEL

Abstract- A multiple-input multiple-output (MIMO) wireless communication system combined with the orthogonal frequency division multiplexing (OFDM) modulation technique, which can achieve reliable high data rate transmission over broadband wireless channels. Channel state information for MIMO Channel systems based on pilot aided arrangement is included in this paper. The estimation of channel at pilot frequencies with conventional Least Square (LS) and Minimum Mean Square (MMSE) estimation algorithms is carried out through Matlab simulation. The performance of MIMO OFDM is evaluated on the basis of Bit Error Rate (BER) and Mean Square Error (MSE) level. Further enhancement of performance can be achieved through maximum diversity Space Time Block Coding (STBC) and Maximum Likelihood Detection at transmission and reception ends respectively. MMSE estimation has been shown to perform much better than LS for the MIMO system using pilot carriers.

Index Terms— LS, MMSE, DFT, MIMO OFDM, Channel Estimation, MIMO-OFDM, Pilot carriers, Diversity, Spatial Multiplexing, Space time coding

1 INTRODUCTION

OFDM (Orthogonal Frequency Division Multiplexing) becoming a very popular multi-carrier modulation technique for transmission of signals over wireless channels. OFDM divides the high-rate series stream into parallel lower rate data and which helping to eliminate Inter Symbol Interference (ISI). It also allows the bandwidth of Subcarriers to overlap without Inter Carrier Interference (ICI) as long as the modulated carriers are orthogonal. OFDM therefore is considered as an efficient modulation technique for broadband access in a dispersive environment.[1] In this new information age, Wireless systems continue to make every effort for ever higher data rates. This goal is particularly challenging for systems that are power, bandwidth, and complexity limited. High data rate and strong reliability systems are becoming the dominant factors for a successful exploitation of commercial networks in wire-less communication. MIMO-OFDM (multiple input multiple output orthogonal frequency division multiplexing), a new wireless broadband technology, has gained great popularity for its capability of high rate transmission, reliability and its robustness against multi-path fading and other channel impairments. The arrangement of multiple antennas at the transition end and reception end results increase in the diversity gain refers the quality of signal and multiplexing gain refers the transmission capacity. Space time block coding used in this paper to transmit multiple copies of a data stream across a number of antennas and to exploit the various received versions of data to improve reliability of data transfer. The major challenge faced in MIMO-OFDM systems is how to obtain the channel state information accurately and promptly for coherent detection of information symbols. In the graph we have shown the advantage of channel estimation compared to that of

no channel estimation for the different SNR levels.

The training-based method channel estimation can be performed by either block type pilots where pilot tones are inserted into all frequency bins within periodic intervals of OFDM blocks or by comb pilots where pilot tones are inserted into each OFDM symbol symbols with a specific period of frequency bins. In an OFDM system ,the transmitter modulates the message bit sequence in to PSK/QAM symbols ,performs IFFT on the symbols to convert them in to time domain signals, and sends them throughout the wireless channel, The channel characteristic distort the received signal, so to recover the transmitted bits at receiver side, the channel effect must be estimated and compensated. (8-10). Each subcarrier can be regulated as an independent channel ,as long as no in-carrier interference occurs, and preserved orthogonality among subcarriers. The orthogonality allows each sub-carrier component of the received signal to be expressed at the subcarriers. So the transmitted signal can be recovered by estimating the channel response just at each sub-carrier. In general the channel can be estimated by using a preamble or pilot symbol known to both transmitter and receiver, which employs various interpolation techniques to estimate the channel response of the subcarriers between pilot tones. In general data signal as well as training signal both can be used for channel estimation. In order to choose the channel estimation technique for the OFDM system under consideration, much different aspect of implementations, including the required performance, computational complexity, and time variation of the channel must be taken in to account. Further, this signal model is transformed into a linear form suitable for the LS (least square) and MMSE (minimum mean square

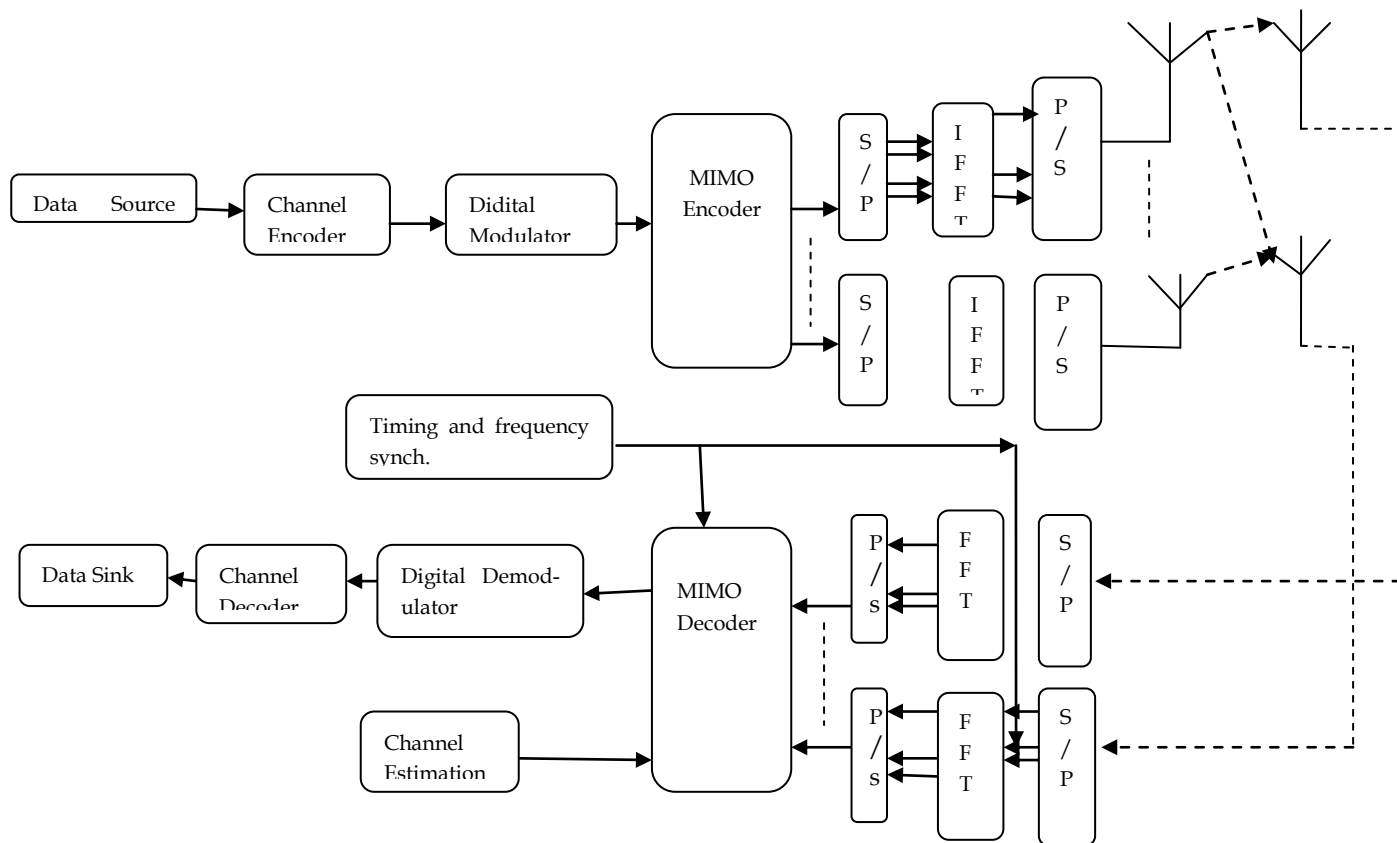

Figure 1: $N_t \times N_r$ MIMO-OFDM System model

error) Estimation algorithm. MMSE has been shown to perform much better than LS.

The organization of the paper is as follows. Section 2 describe the system models of MIMO OFDM systems. Section 3 provided the performances of LS and MMSE algorithms in both the systems, simulation results & graphs are presented in Section 4 Conclusion is given in Section 5

2 MIMO CHANNEL MODEL

Fig. 1 depicts a block diagram of the MIMO OFDM system. We consider MIMO-OFDM systems with two transmit antennas and two receive antennas. The total number of subcarriers is N . Basically, the MIMO-OFDM transmitter has N_t parallel transmission paths which are very similar to the single antenna OFDM system, each branch performing serial-to-parallel conversion, pilot

insertion, N -point IFFT and cyclic extension before the final TX signals are up-converted to RF and transmitted. It is worth noting that the channel encoder and the digital modulation, in some spatial multiplexing systems, can also be done per branch, where the modulated signals are then space-time coded. Subsequently at the receiver side, the CP is removed and N -point FFT is performed per receiver branch. Next, the transmitted symbol per TX antenna is combined and outputted for the subsequent operations like digital demodulation and decoding. Finally all the input binary data are recovered with certain BER. As a MIMO signalling technique, N_t different signals are transmitted simultaneously over $N_t \times N_r$ transmission paths and each of those N_r received signals is a combination of all the N_t transmitted signals and the distorting noise. It brings in the diversity gain for enhanced system capacity as we desire[7]. MIMO OFDM system model which is consist of $x_t ; t=0 \dots N-1$, transmitted sig-

nals and yt received signals. The transmitted signals xt are taken from multi amplitude signal constellation The channel impulse response of the system is calculated using the equation given below.

$$g(t) = \sum_m \alpha_m \delta(t - \tau_m \cdot T_s) \dots \dots \dots (1)$$

Where T_s is the sampling interval, τ_m is the delay, α_m is the amplitude.

The received signal is given as

$$Y = XFg + n$$

Where X is the matrix element of x on its diagonal and $x = [x_0, x_1, \dots, x_{N-1}]^T$ and n is the noise. $n = [n_0, n_1, \dots, n_{N-1}]^T$

$$F = \begin{bmatrix} W_N^{00} & \dots & W_N^{0(N-1)} \\ \vdots & \ddots & \vdots \\ W_N^{(N-1)0} & \dots & W_N^{(N-1)(N-1)} \end{bmatrix}$$

$$W_N^{nk} = \frac{1}{\sqrt{N}} e^{-j2\pi \frac{nk}{N}} \dots \dots \dots (2)$$

$$g = [g_0, g_1, \dots, g_{N-1}]^T$$

3 TRAINING SYMBOL-BASED CHANNEL ESTIMATION

Training symbols can be used for channel estimation, usually providing a good performance. However, their transmission efficiencies are reduced due to the required overhead of training symbols such as preamble or pilot tones that are transmitted in addition to data symbols. The least-square (LS) and minimum-mean-square-error (MMSE) techniques are widely used for channel estimation when training symbols are available [9]. We assume that all subcarriers are orthogonal. Then the training symbols for N subcarriers can be represented by Matrix,

$$X = \begin{bmatrix} X[0] & 0 & \dots & 0 \\ 0 & X[1] & & \vdots \\ \vdots & & \ddots & 0 \\ 0 & \dots & 0 & X[N-1] \end{bmatrix}$$

Where $X[k]$ denotes a pilot tone at the kth subcarrier with $E\{X[k]\} = 0$ and $\text{Var}\{Z[k]\} = \sigma_z^2, k=0,1,2,\dots,N-1$. Channel gain is $H[k]$ for each subcarrier k, the received training signal $y[k]$ can be represented by,

$$Y \triangleq \begin{bmatrix} X[0] & 0 & \dots & 0 \\ 0 & X[1] & & \vdots \\ \vdots & & \ddots & 0 \\ 0 & \dots & 0 & X[N-1] \end{bmatrix} \begin{bmatrix} H[0] \\ H[1] \\ \vdots \\ H[N-1] \end{bmatrix} + \begin{bmatrix} Z[0] \\ Z[1] \\ \vdots \\ Z[N-1] \end{bmatrix} \dots \dots \dots (3)$$

$$Y = XH + Z$$

Where H is a channel vector given as $H = [H[0], H[1], \dots, H[N-1]]^T$ and Z is a noise vector given as $Z = [Z[0], Z[1], \dots, Z[N-1]]^T$ with $\text{Var}\{Z[k]\} = \sigma_z^2, k=0,1,2,\dots,N-1$.

3.1 LS Channel Estimation

The least square channel estimation method finds estimate \hat{H} in such a way that the following function can be minimized.

$$J(\hat{H}) = \|Y - XH\|_2^2 \dots \dots \dots (4)$$

$$= (Y - XH)_H^H (Y - XH)$$

$$= Y^H Y - Y^H X \hat{H} - \hat{H}^H X^H Y + \hat{H}^H X^H X \hat{H}$$

derivation of the function with respect to \hat{H} to zero,

$$\frac{\partial J(\hat{H})}{\partial \hat{H}} = -2(X^H Y) + 2(X^H X \hat{H})^* = 0 \dots \dots (5)$$

we have $X^H X \hat{H} = X^H Y$, which gives the solution to the LS channel estimation as,

$$\hat{H}_{LS} = (X^H X)^{-1} X^H Y = X^{-1} Y \dots \dots \dots (6)$$

$$\hat{H}_{LS} = \frac{Y^{[K]}}{X^{[K]}} \quad K=0,1,2,3,\dots,N-1$$

The mean square error (MSE) of this LS channel estimation is given as

$$\begin{aligned} \text{MSE}_{LS} &= E\{(H - \hat{H}_{LS})^H (H - \hat{H}_{LS})\} \\ &= E\{(H - X^{-1} Y)^H (H - X^{-1} Y)\} \\ &= E\{(X^{-1} Z)^H (X^{-1} Z)\} \\ &= E\{Z^H (X X^H)^{-1} Z\} \\ &= \frac{\sigma_z^2}{\sigma_x^2} \dots \dots \dots (7) \end{aligned}$$

The MSE of LS in above equation is inversely proportional to the SNR σ_z^2 / σ_x^2 , which implies that it may be subject to noise enhancement, Due to its simplicity the LS is widely used for channel estimation.

3.2 MMSE Channel estimation

In MMSE channel estimation weight matrix W define $\hat{H} = W \tilde{H}$, refer fig 2 MSE of the channel estimate \hat{H} is given as,

$$J(\hat{H}) = E\{\|e\|^2\} = E\{\|H - \hat{H}\|^2\} \dots \dots (8)$$

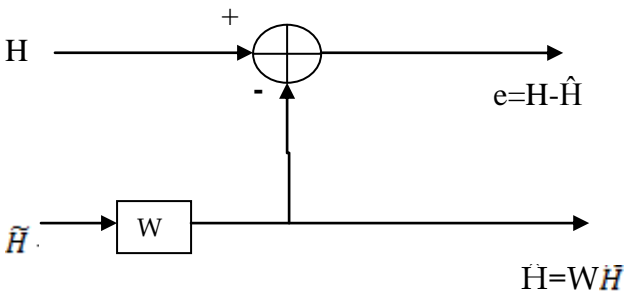

Then the MMSE Channel Estimation method finds a better linear estimate in terms of W in such a way that the MSE is minimized.

The orthogonality principle states that the estimation error vector $e = H - \hat{H}$ is orthogonal to \tilde{H} ,

$$\begin{aligned} E\{e \tilde{H}^H\} &= E\{(H - \hat{H}) \tilde{H}^H\} \\ &= E\{(H - W \tilde{H}) \tilde{H}^H\} \\ &= E\{H \tilde{H}^H\} - W E\{\tilde{H} \tilde{H}^H\} \\ &= R_{H\tilde{H}} - W R_{\tilde{H}\tilde{H}} = 0 \dots \dots (9) \end{aligned}$$

R_{AB} is the auto correlation matrix of $N \times N$ matrices of A and B

$$W = R_{H\tilde{H}} R_{\tilde{H}\tilde{H}}^{-1} \dots \dots \dots (10)$$

Where $R_{\tilde{H}\tilde{H}}$ is the auto correlation matrix of \tilde{H} is given as

$$\begin{aligned} R_{\tilde{H}\tilde{H}} &= E\{\tilde{H} \tilde{H}^H\} \\ &= E\{X^{-1} Y (X^{-1} Y)^H\} \\ &= E\{(H + X^{-1} Z)(H + X^{-1} Z)^H\} \\ &= E\{H H^H + X^{-1} Z H^H + H Z^H (X^{-1})^H + X^{-1} Z Z^H (X^{-1})^H\} \\ &= E\{H H^H\} + E\{X^{-1} Z Z^H + H Z^H (X^{-1})^H\} \\ &= E\{H H^H\} + \frac{\sigma_z^2}{\sigma_x^2} I \dots \dots \dots (11) \end{aligned}$$

And $R_{H\tilde{H}}$ is the crosscorrelation matrix between the true channel vector and temporary channel estimate vector in the frequency domain.

$$\begin{aligned} \hat{H} = W \tilde{H} &= R_{H\tilde{H}} \tilde{H} - R_{\tilde{H}\tilde{H}}^{-1} \tilde{H} \\ &= R_{H\tilde{H}} \tilde{H} (R_{H\tilde{H}} + \sigma_z^2 / \sigma_x^2 I)^{-1} \tilde{H} \dots \dots (12) \end{aligned}$$

4 SIMULATION RESULTS AND GRAPHS

4.1 No channel estimation vs. LS channel estimation

IFFT SIZE	SNR	BER
128	16	0.02375
256	16	0.1542
512	16	0.015
1024	8	0.000833

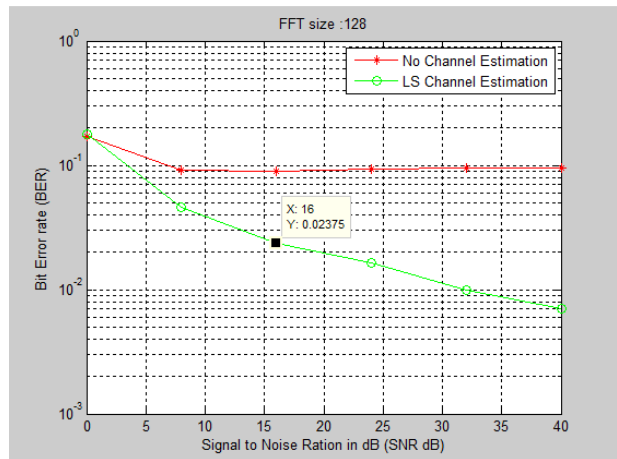

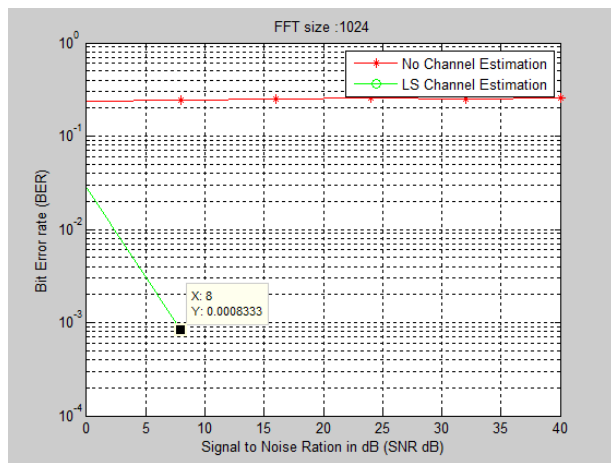
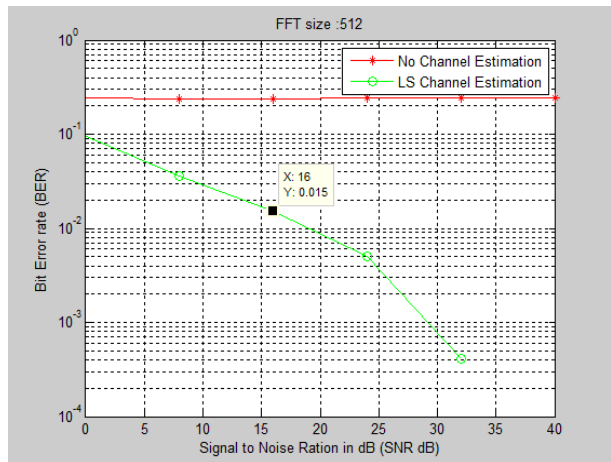
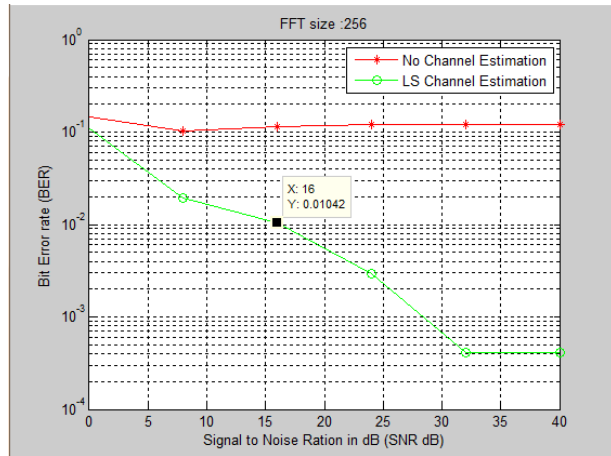

4.2 LS vs MMSE based on MSE(mean Square Error) different values of FFT

FFT SIZE	SNR	MSE(LS)	MSE (MMSE)
64	15	0.1563	0.03133
128	15	0.1704	0.02208

256	15	0.04077	0.007673
-----	----	---------	----------

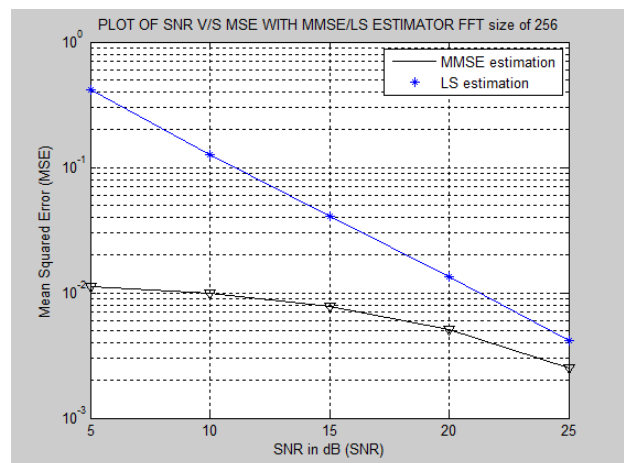
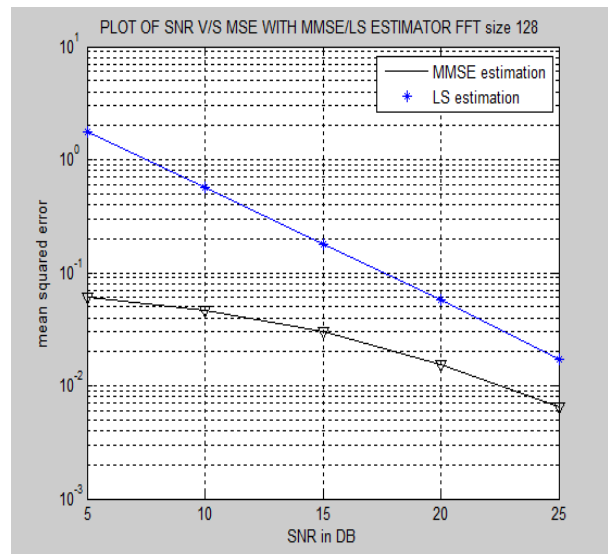
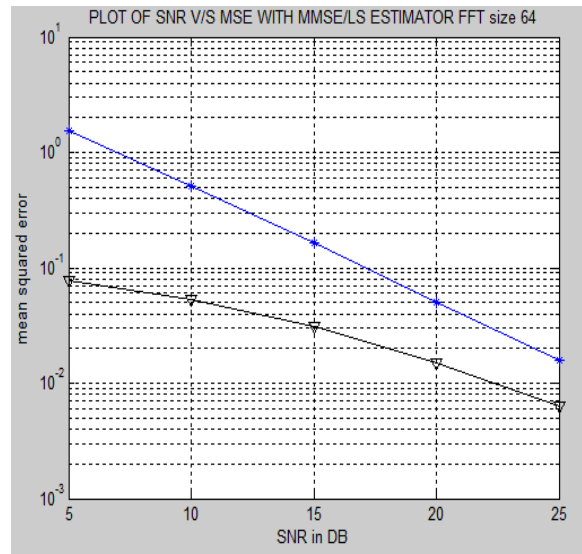

4.3 LS vs MMSE based on SER (symbol error rate) different value of FFT

See command window for detail values.

FFT SIZE	SNR	SER(LS)	SER (MMSE)
64	20	0.3784	0.3046
128	20	0.8297	0.7337
256	20	1.885	1.885

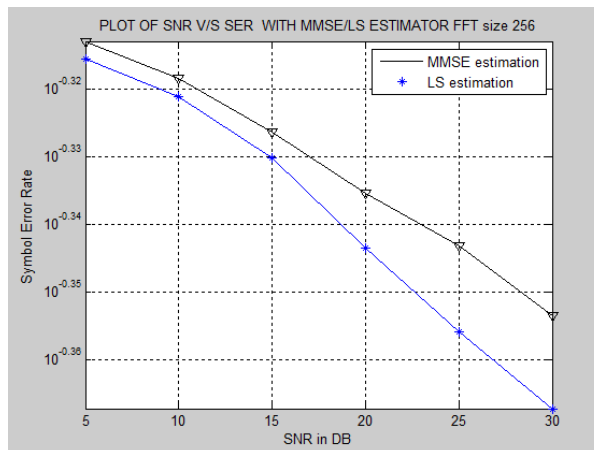

5 CONCLUSION

In this paper, we propose to evaluate the performance of LS and LMMSE estimation techniques. For Downlink systems under the effect of the IFFT size, channel length, SNR and BER. The cyclic prefix inserted at the beginning of each OFDM symbol is usually equal to or longer than the channel length in order to suppress ICI and ISI. However, the CP length can be shorter than the channel length because of some unforeseen behavior of the channel. Simulation results show that LS channel estimation is better than that of NO channel estimation. When LS is compared to MMSE estimation MMSE shows better performance than LS. As the IFFT size increased the significant improvement in BER but increasing the IFFT size will result in more computational load. LS is easy to implement and MMSE is a bit complex but gives significant increase in SNR value when compared to LS length, the LMMSE performs better.

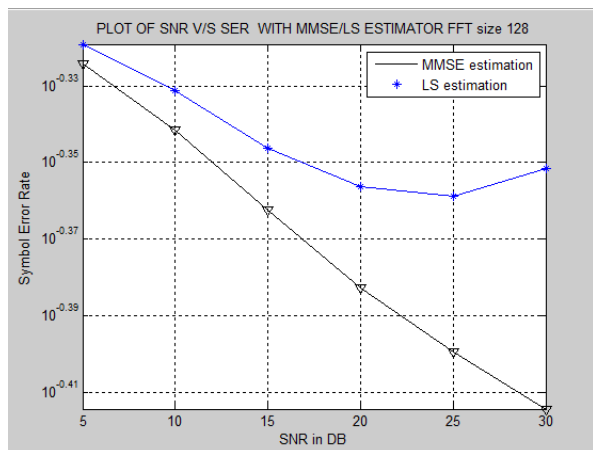
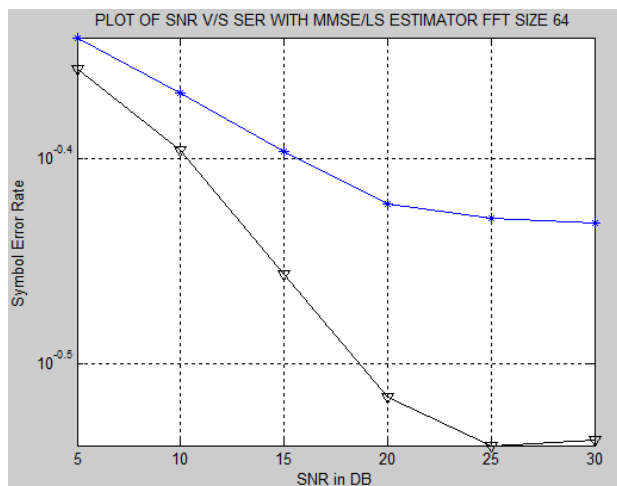

REFERENCES

- [1] MIMO-OFDM Channel Estimation Using Pilot Carriers International Journal of Computer Applications (0975 - 8887) Volume 2 - No.3, May 2010, Kala Praveen Bagadi Ph.D Student, Dept. of Electrical Engineering NIT Rourkela, India Prof. Susmita Das Associate Professor Dept. of Electrical Engineering NIT Rourkela, India
- [2] Ramjee Prasad, "OFDM for Wireless Communications Systems", Artech House, Inc. Publications.
- [3] Ezio Biglieri, Robert Calderbank, Robert Calderbank, Anthony Constantinides, Andrea Goldsmith, Arogyaswami Paulraj, H. Vincent Poor, "MIMO Wireless Communications", Cambridge Press.
- [4] Channel Estimation Techniques Based on Pilot Arrangement in OFDM Systems, Sinem Coleri, Mustafa Ergen, Anuj Puri, and Ahmad Bahai, IEEE TRANSACTIONS ON BROADCASTING, VOL. 48, NO. 3, SEPTEMBER 2002 223
- [5] Broadband MIMO-OFDM Wireless Communications GORDON L. STÜBER, FELLOW, IEEE, JOHN R. BARRY, MEMBER, IEEE, STEVE W. MCLAUGHLIN, SENIOR MEMBER, IEEE, YE (GEOFFREY) LI, SENIOR MEMBER, IEEE, MARY ANN INGRAM, SENIOR MEMBER, IEEE, AND THOMAS G. PRATT, MEMBER, IEEE 0018-9219/04\$20.00 © 2004 IEEE, PROCEEDINGS OF THE IEEE, VOL. 92, NO. 2, FEBRUARY 2004

- [6] MIMO-OFDM Wireless Communications with MATLAB_ Yong Soo Cho, Jaekwon Kim, Won Young Yang and Chung G. Kang_ 2010 John Wiley & Sons (Asia) Pte Ltd
- [7] MIMO-OFDM COMMUNICATION SYSTEMS: CHANNEL ESTIMATION AND WIRELESS LOCATION by Zhongshan Wu B.S., Northeastern University, China, 1996 M.S., Louisiana State University, US, 2001 May 2006
- [8] Cimini, L.J. (1985) Analysis and simulation of a digital mobile channel using orthogonal frequency-division multiplexing. *IEEE Trans. Commun.*, 33(7), 665-675.
- [9] Tufvesson, F. and Maseng, T. (May 1997) Pilot assisted channel estimation for OFDM in mobile cellular systems. *IEEE VTC'97*, vol. 3, pp. 1639-1643.
- [10] van de Beek, J.J., Edfors, O., Sandell, M. et al. (July 1995) On channel estimation in OFDM systems. *IEEE VTC'95*, vol. 2, pp. 815-819.